

**City of Spirit Lake
Public Works Department – Code Enforcement Division**

REQUIREMENTS FOR WORKING IN THE PUBLIC RIGHT-OF-WAY

Introduction – The public right-of-way (R.O.W.) is the portion of city property that abuts your front yard or alley with its width containing both sides of the street. The R.O.W. is owned by the City but maintained by the adjacent property owner.

Working in the public right-of-way requires a permit, which is obtained at the Public Works Department. A completed Plot Plan indicating the work would suffice as an application. Here are a few of the most common at-grade installations, which include sidewalks, approaches and curb cuts.

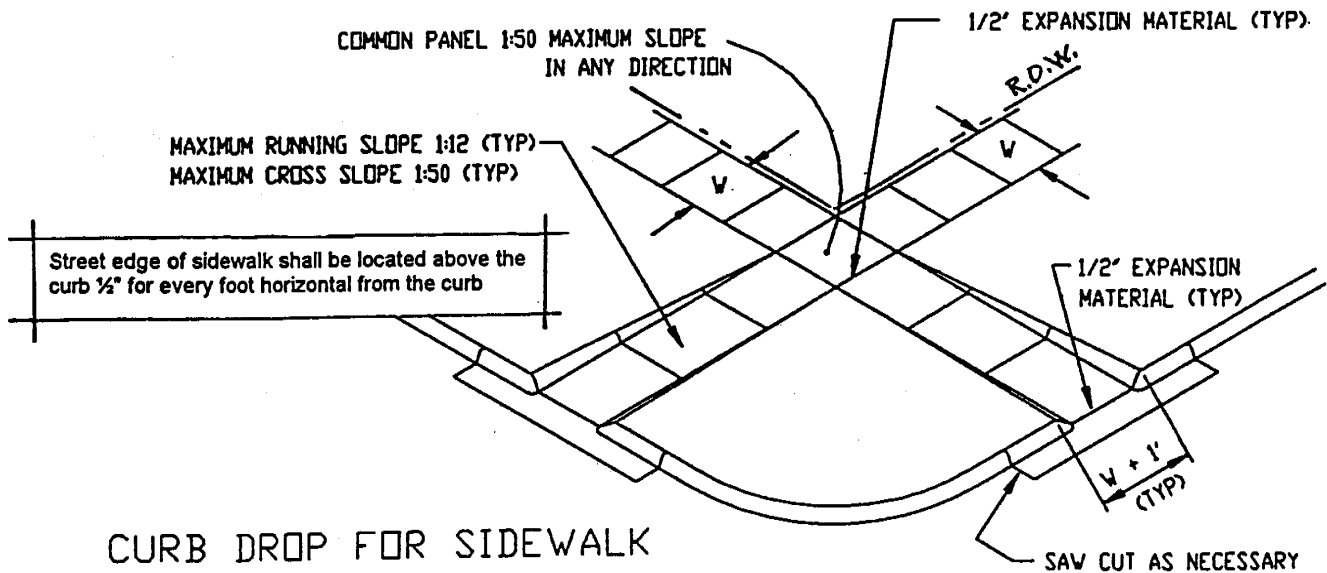

CURB DROP FOR SIDEWALK

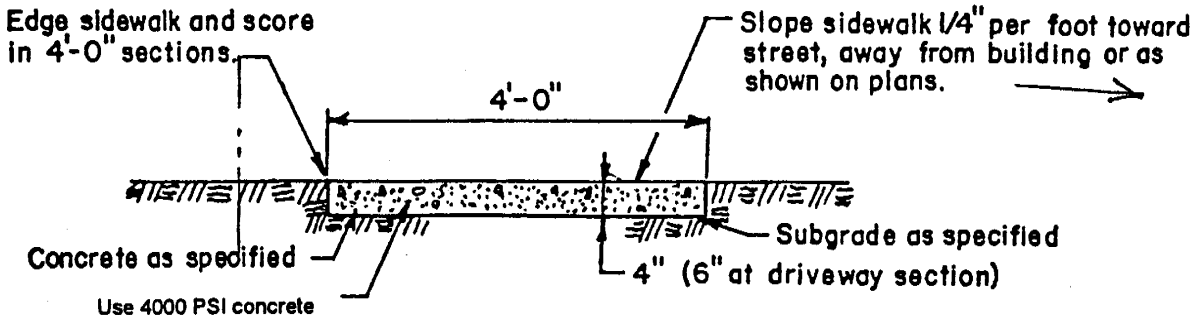

CROSS SECTION

DRIVEWAY REGULATIONS

Single Family Residences

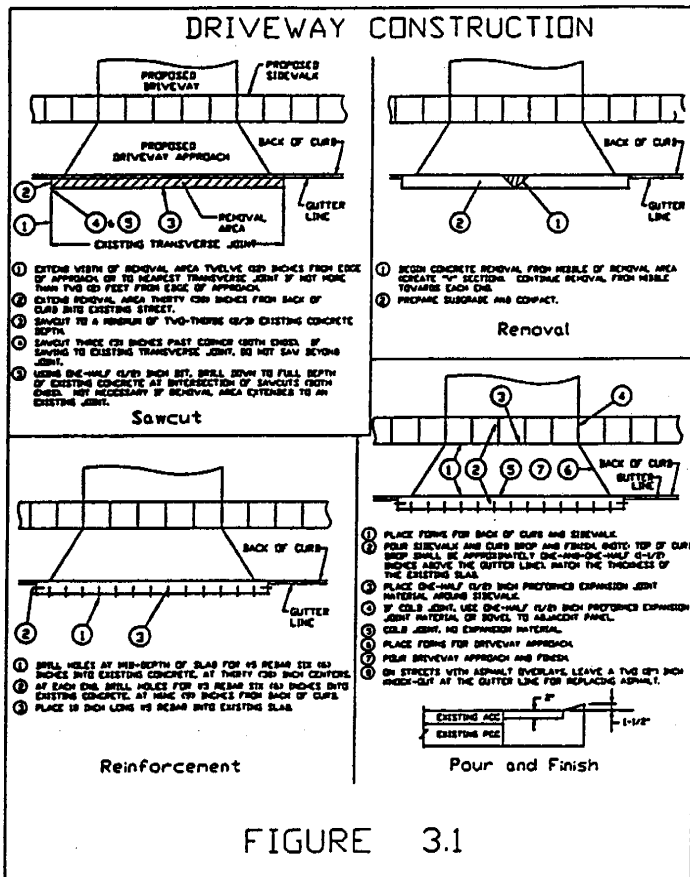
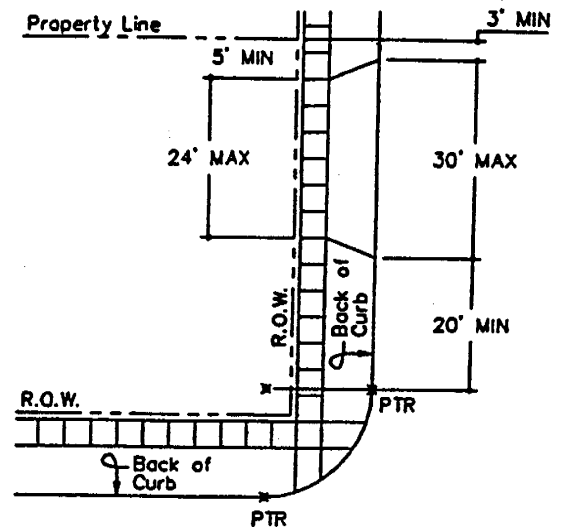
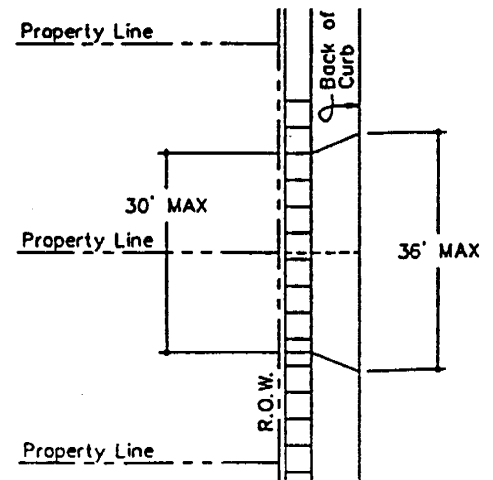

FIGURE 3.1



One Driveway



Shared Driveway
Adjacent Single Families

Inspections/Questions – The owner or contractor is responsible for calling the Public Works Department to arrange for your inspection. For other installations or for more details, consult the Spirit Lake Municipal Design Standards. For further information, you may stop in or call the Engineering Department in the Public Works Department at 366-1871.